



# Tack and Equipment guide

Taken from ANWE rules  
<https://anwe.org.au/>

## Tack and Attire:

- The appropriateness (legality and safety) of both tack and attire will be checked prior to the competitor's entry into the competition arena by an official appointed by the Organising Committee.
- No changes of tack or attire are allowed for the duration of the three compulsory phases with exceptions to those noted below.
- Approved rider attire is National Working Equitation, Provincial or Club attire. A rider must not mix and match attire.
- Same tack/attire must be worn in all compulsory phases, except jackets, spurs, whips and horse boots.
- Riders participating in competitions or events of ZAWE are strongly recommended to wear an approved safety helmet with the chin strap fastened. All safety helmets are to conform with Equestrian standards
- It is the responsibility of riders to comply with the Conditions of Entry when participating in any ZAWE National, State or Club competition.
- Riders under the age of 18 must wear an approved safety helmet in all phases of all competitions and whenever riding a horse at any ZAWE (or ZAWE affiliate's) event.

# Attire Options

It is the expectation that all riders in ZAWE competition wear a uniform. A uniform demonstrates a commitment to present the sport of working equitation in the best possible manner. The wearing of a uniform also demonstrates respect for Judges and fellow riders.

## National Working Equitation Attire -

- Navy / black safety helmet
- cream/champagne moleskins, breeches, or jodhpurs
- navy / black jacket or vest
- white shirt
- navy, white & red striped tie, or white stock
- long black or brown boots
- short black or brown boots (these can be worn with matching leather gaiters)
- navy saddle cloth with red binding with white piping.

Provincial Working Equitation Attire – MUST be approved in the relevant affiliated Provincial Association minutes.

## Working Equitation Club Attire –

<b>Traditional English</b>	<b>Traditional Western</b>
Jodhpurs /Breeches (solid colours) Long sleeve shirt (button up, UV base layer not T shirt) Short or long boots (shorts boots can be used with gaitors) Hair should be neat and tidy Gloves optional	Long Jeans, Pants, Trousers with a belt Long sleeve shirt with colour (band, standup, tuxedo, etc) Boots with heel Gloves optional Chaps Optional

- Breed attire (see bits allowed)
- Traditional English Competition Attire (showing / dressage).

# Attire Options - SANESA

## **SANESA – level 0, 1, 3**

Long pants / Jeans / Jodphurs / Tights or Breeches of a solid colour  
School shirt, School sports shirt, SANESA shirt or long sleeve shirt (Button up, UV base layer not T shirt)  
Shoes with heels  
Traditional English Competition Attire  
Traditional Western Attire

## **SANESA – level 5**

Traditional English Competition Attire (showing /dressage)  
Traditional Western Competition Attire

# Tack Options

Any style of bridle or saddle (with approved National or Club saddle cloth) is permitted. All tack must be well fitting so as not to cause pain or distress to the horse.

- Spurs are to be blunt competition spurs. Blunt rowels are acceptable.
- Whips - Whips may be used in the normal way for all levels with the exception of Consagrados 1 and Masters. Permissible maximum length for whips is 1.2 metres and 1 metre for ponies. The tassel is included when measuring the whip.
- The whip must not be secured to the horse or tack, it must be held by hand. Only one whip is permitted at all times when riding at the venue.
- Bits as per Equestrian Australia for dressage competitions

The fitting of the curb and chain for the Portuguese, Kimblewick, English Pelham and the Bit & Bradoon is as follows:

- The curb strap or chain should be done up so that when the reins activate the chain or strap, the shanks of the bit do not rotate beyond 45 degrees and the width of two fingers (3cm) exists between the horse's chin groove and the strap or chain to estimate the tightness of the chain when not activated.
- Rubber guards are allowed.



**Tack not permitted** - riding in any of the tack listed below on the competition grounds on the day of competition will result in immediate elimination.

Running/standing martingales, running reins, chambon, de Gogue, tongue ties, blinkers, ear plugs (may be used for presentations) or ANY equipment that the Ground Jury for the relevant competition determines is against the intent and general principles of working equitation.

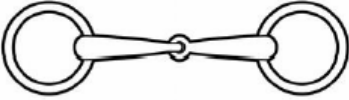
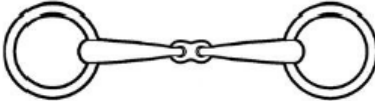

# Permitted bits according to dressage rules

## 5.20 Permitted bits

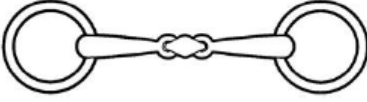
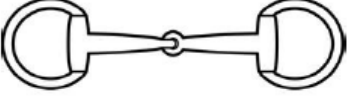
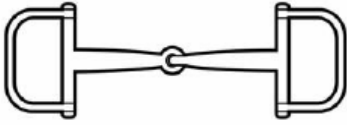
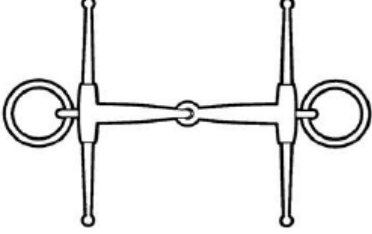
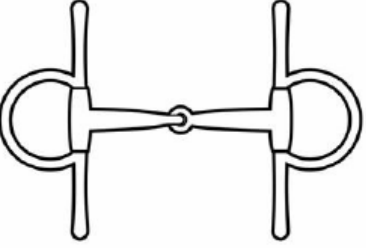
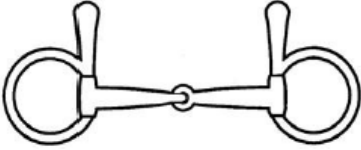

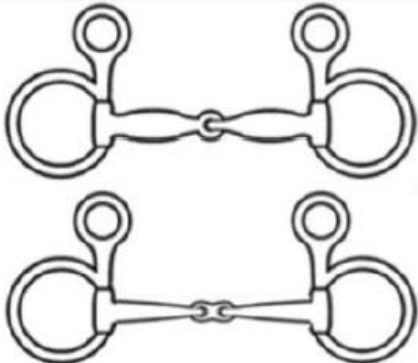
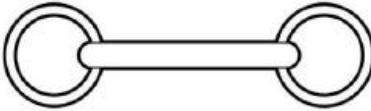
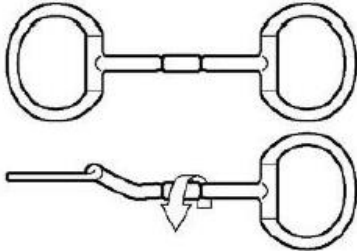

Refer to EA equipment annex for illustration of permitted bits - <http://www.equestrian.org.au>

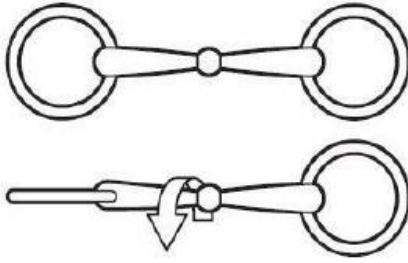
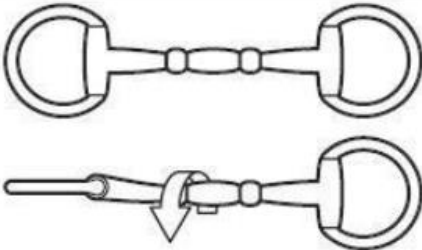
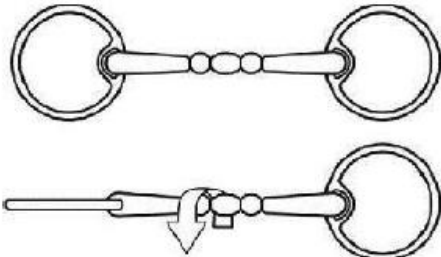
1. Loose ring snaffle	
2. Snaffle with jointed mouthpiece where middle piece must be rounded. Egg butt sides also permitted	
3. Snaffle with jointed mouthpiece where middle piece must be rounded. Egg butt sides also permitted	
4. Snaffle with jointed mouthpiece where middle piece must be rounded. Egg butt sides also permitted.	
5. Egg butt snaffle	
6. Racing snaffle (D ring)	
7. Loose- ring snaffle with cheeks (fulmer) (keepers permitted)	
8. Egg- but snaffle with cheeks (keepers permitted)	
9. Snaffle with upper cheeks only	



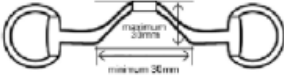

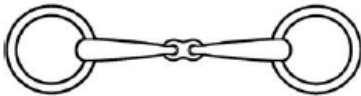
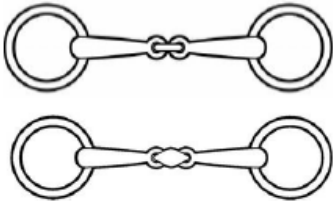

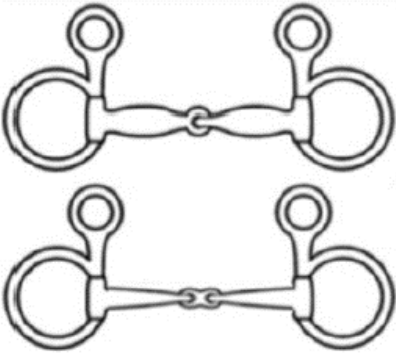
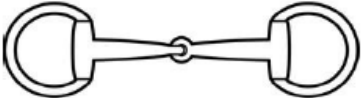
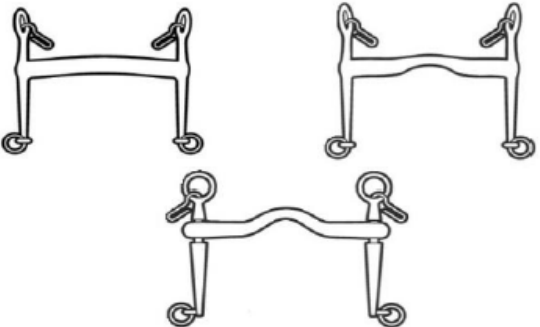
# Permitted bits according to dressage rules, cont...

<p>10. Hanging cheek snaffle (single or double joint only)</p>	
<p>11. Straight bar snaffle. Permitted also with mullen mouth and with egg butt rings</p>	
<p>12. Snaffle with rotating mouthpiece</p>	
<p>13. Snaffle with rotating middle piece</p>	
<p>14. Rotary bits single jointed</p>	
<p>15. Rotary bits double jointed</p>	
<p>16. Rotary bit with rotating middle piece and lopped rings</p>	

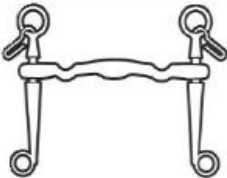
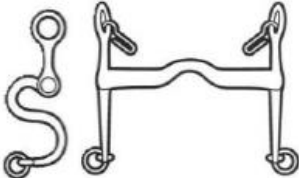
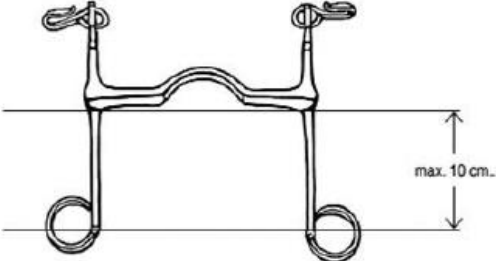





# Permitted bits according to dressage rules, cont...

<p>Measurement for deviation to allow tongue relief in snaffle with rotating mouthpiece</p>	
<p><b>Double bridles bits - bridoons</b></p>	
<p>17. Loose-ring bridoon bit</p>	
<p>18. Loose-ring bridoon bit with jointed mouthpiece where the middle piece is rounded</p>	
<p>19. Loose-ring bridoon bits with jointed mouthpieces where the middle piece is rounded</p>	
<p>20. Bridoon bit with rotating middle piece</p>	
<p>21. Bridoon bit with hanging cheeks (single and double joint only)</p>	
<p>22. Egg-butt bridoon bit</p>	
<p><b>Curbs (curb chain hooks may be fixed)</b></p>	
<p>23. Half-moon curb bit (top left)          Half-moon curb bit with straight cheeks and port (top right and bottom)          Curb bit with port and sliding mouthpiece (Weymouth). A curb bit with rotating lever arm also permitted (bottom)</p>	

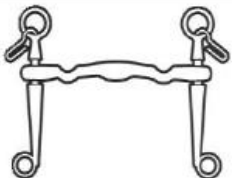
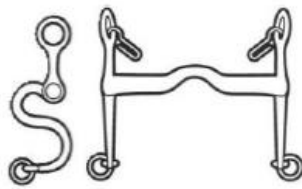
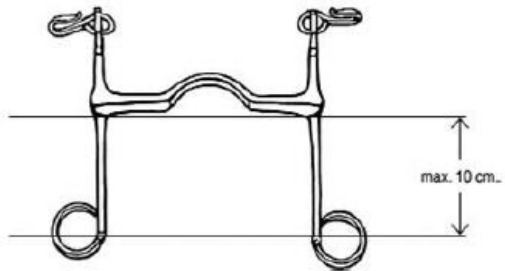

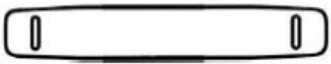
# Permitted bits according to dressage rules, cont...

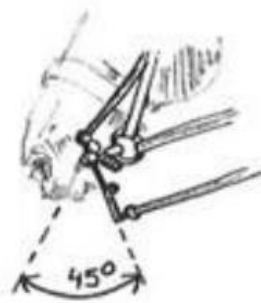
<p>24.Variation of the two sets of bits above</p>	
<p>25.Curb bit with S-curved cheeks</p>	
<p>26.Length of lever arm is limited to 10cm</p>	
<p>27.Lip strap</p>	
<p>28.L Leather cover for curb chain</p>	
<p>29.Rubber or sheepskin cover for curb chain</p>	
<p>30.Curb chain (metal, leather or combination) – refer to rule 5.11.2</p>	
<p>31.(a) Curb Chain (refer 5.11.4.2)</p>	
<p>31.(b) Curb Chain (refer 5.11.4.2)</p>	

# Permitted bits according to dressage rules, cont...

<p>24.Variation of the two sets of bits above</p>	
<p>25.Curb bit with S-curved cheeks</p>	
<p>26.Length of lever arm is limited to 10cm</p>	
<p>27.Lip strap</p>	
<p>28.L Leather cover for curb chain</p>	
<p>29.Rubber or sheepskin cover for curb chain</p>	
<p>30.Curb chain (metal, leather or combination) – refer to rule 5.11.2</p>	
<p>31.(a) Curb Chain (refer 5.11.4.2)</p>	
<p>31.(b) Curb Chain (refer 5.11.4.2)</p>	

# Additional Bits

<p>Portuguese curb (shank less than 10cm), consistent with this picture and must meet the measurements on the diagram of a curb bit.</p>	
<p>Kimblewick straight (with or without port) jointed or halfmoon.</p>	
<p>Kimblewick straight (with or without port) jointed or halfmoon.</p>	

The above bits must comply with the measurements below where applicable:

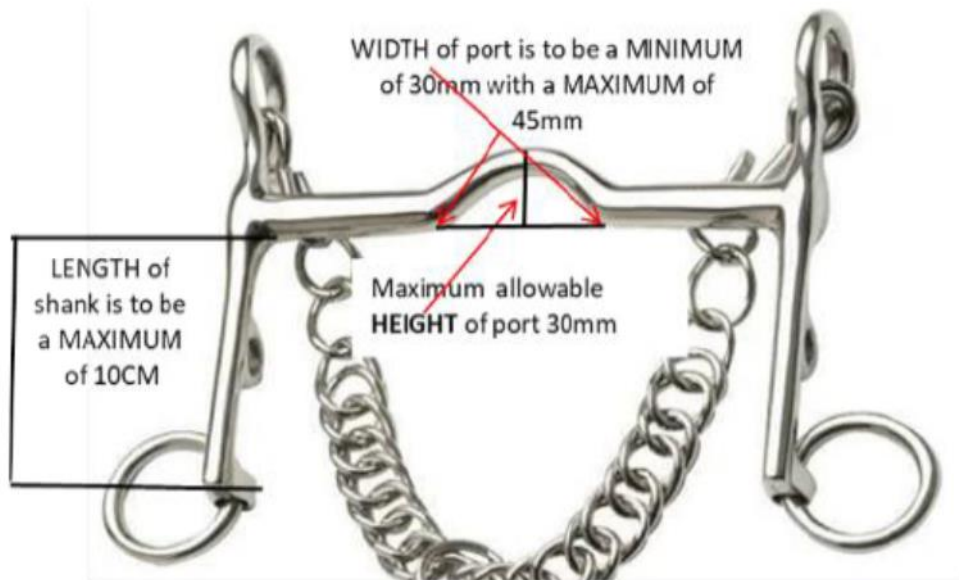

# Additional Bridles

Bitless bridle - must not self-tighten



Micklem bridle with a bit and without clips. The noseband must fit with two fingers vertically under the chin. This allows the bridle to be correctly and functionally fitted.



Bosal – minimum diameter 5/8 of an inch, flexible non-metal core, well fitted so as not to cause any rubbing or irritation to the horse and meet the rule



# Equipment

- Horse leg protector boots are allowed at all levels except Dressage phase. No bandages are permitted.
- Hoof boots are permitted in all phases
- Nosebands if used MUST be fitted to allow two fingers standing vertically on the bridge of the nose (approximately 3cm).
- Nose nets are permitted to be used in competitions and warm-up on written approval by ZAWE. Permission will be given on a case-by-case basis.
- Applications with a supporting letter from a veterinarian are to be sent to the ZAWE Secretary.
- If approved, the rider of the horse with the nose net must send a copy of the ZAWE approval letter with entries.
- The nose net must be made of transparent material as per the example.
- The nose net must not cover the mouth or bit.
- Fly Hoods are permitted to be worn under the following conditions:
  - The fly hood must not cover the horse's eyes.
  - The fly hood must be clearly made from a material which does not provide any sound reduction.
  - No materials may be used to plug the horse's ears
  - Failure to present to the gear steward for fly hood inspection at the completion of a phase will incur elimination
  - The Gear Steward will verify that no additional insulation from the manufactured state has been inserted and that ear plugs have not been inserted.
- Monkey grips are permitted on saddles in all phases.



# Fitting a bosal/hackamore

Proper hackamore fit is important for correct function. A hackamore is made up of a noseband with nose button (1) that is often called a bosal, a hanger (4) or headstall and a single rein called a mecate (3). Depending on the region where you live, the words bosal and hackamore may be used interchangeably.



Common materials used in construction of the hackamore are rawhide, kangaroo, latigo, rope and horse hair. The rawhide, kangaroo and latigo are cut into even strips, bevelled and braided around a flexible but firm core commonly made of coiled rawhide. The nose button and heel knot (2) are also made of braided rawhide, kangaroo or latigo.

Rope hackamores are made of a single piece of rope and usually have a nose button of braided rawhide, latigo or nylon cord and a heel knot of braided rawhide. Horse hair hackamores are made of twisted mane hair with a rawhide heel knot.

The hangers and headstalls are generally made of leather. The hangers are made of a single, narrow piece of leather and may be held out of the eye with a leather string going under the cheek. Headstalls usually have a brow band with fiador which helps to keep the headstall away from the horse's eyes. Mecates are made of twisted horse hair or nylon rope and should be close to the same diameter as the bosal.

General guidelines for adjusting the hackamore correctly are:

- a) Adjust it so it lies evenly on the nose between the inside corner of the eye and the bottom of the nostril.
- b) The mecate should be tied to the bosal with just enough wraps that you can fit 2 fingers between the chin and the mecate knot. The mecate knot should rest on the chin when the horse is at rest.
- c) It's important not to use a bosal that's too long for your horse. If the heel knot hits the horse's chest when the mecate is pulled and/or he gives his head to the pressure of the pull you know the bosal is too long.

Use of the Bosal and Mecate in the Cattle phase is subject to approval of the Organising Committee prior to the commencement of the competition.

# Fit And Adjustment

Properly fitted and adjusted, the hackamore/bosal conforms to the nose and sides of the face more akin to the fit of a custom hat that doesn't squeeze or pinch. This allows the bosal to focus on the fatty tissues of the sides of the face more than the bony structures. Nothing should be tight, but there should be as little space as possible in these areas to avoid wobble, rubbing and lag time to receive the next signal.

For the horse's comfort and to promote real progress, we want no pain or built-in points of pressure. The entire inside of the hackamore's body must be smooth and properly made. The hackamore needs to be tied up correctly with the mecate and the hanger adjusted appropriately. The mecate should be untied and allowed to hang loosely when not in use.

There must be room enough under the jaw for the lift and release action of the hackamore. Any further lift than parallel to the ground, is too much and should be avoided

Correctly made and positioned, small side buttons not only keep the hanger in place to function well, but they also help lessen more potential wobble, static and irritation. The action of the bosal is freed.

If “cherries” or skinned, sore spots from the bosal on the horse’s face.

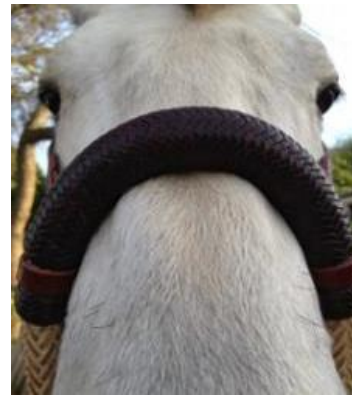

*An ill-fitting bosal. Notice the gaps all around the face, somewhat like a hula hoop. Also note how the weight of the bosal is entirely on top of the sensitive bony structure of the face.*

*A well-fitting bosal. Notice the close fit that follows the contour of the horse's face.*

Underneath, there needs to be a space between the horse's jaw and the mecate knot above the bosal's heel knot to allow for the lift and full release. This width will vary from horse to horse.



# Mecate Rein

The mecate rein must be secured as pictured below.

